



engineering art in dimensional metrology



Product Catalogue Ver 1.0

Air Snap Gauge

Air Snap Gauge



Air snaps are designed for those difficult to reach or "between centers" diameter measurements. Often, air snaps gage a part while it is engaged in the machine tool. Also Snap gages are ideal for production settings where specific diametrical or thickness measurements must be repeated frequently with precision and accuracy.

 10mm to 150mm

 Metric & Imperial

 Customisation available

 Carbide | Steel

Specifications

Product Information

- Range available from 10 mm to 150 mm with carbide resting pads.
- Provided with Master Setting Plug (higher & lower).
- Also offered to suit different makes, as per requirement.

Technical Specifications

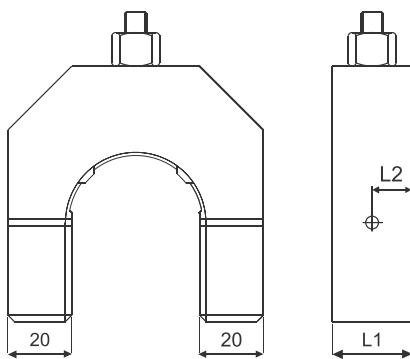

Material	Range		L1		L2	
	From	To	Through hole	Blind hole	Through hole	Blind hole
Steel with Carbide rest	Φ10	Φ150	20	20	10	5.5

* All figures in mm

KCP Air Gauges

KCP Air Gauges are indispensable tool for precision batch and mass production. As tolerances have gotten tighter on the shop floor, air gauging is often the only way to make the check fast and easy for the operator.

Air gauge system is a non-contact gauging system and thereby it has longer life due to minimal frictional wear.

Two setting masters ensure linearity online as well as magnification.

KCP offers a wide range of Air gauging with provision of 2 jets, 3 jets & 4 jets configurations to air probes making it best suitable for internal as well as external dimensions, average diameter, taper, ovality & face run-out.

Air gauges are also suitable for checking relative dimension such as flatness, parallelism, center distance, squareness & concentricity.

Features of KCP Air Snap Gauge

- Very high accuracy i.e. end of assumptions
- No subjectivity
- Repeatability
- Ease of operation
- Self cleaning ability &
- Very fast response time



NABL

Certificate No. : C-0432

KCP Air Snap Gauge is supplied with Calibration Certificate issued from its accredited calibration lab.

precision begins here...



K C Precision

M 107/5/2, MIDC Waluj, Aurangabad 431136 (MS) INDIA. Ph: +91 (0)240 2555895 Telefax: +91 (0)240 2555898

Email: sales@kcpindia.com Web: www.kcpindia.com